



**28" and 48" Digital Level**  
**Model Nos. 40-6028 & 40-6048**



# Instruction Manual

*Congratulations on your choice of this Digital Level. We suggest you read this instruction manual thoroughly before using the instrument. Save this instruction manual for future use.*

## Table of Contents

- |                                 |                               |
|---------------------------------|-------------------------------|
| 1. Kit Contents                 | 5. Using the Product          |
| 2. Features and Functions       | 6. Self-Check and Calibration |
| 3. Location of Parts/Components | 7. Technical Specifications   |
| 4. Operating Instructions       | 8. Care and Handling          |
|                                 | 9. Product Warranty           |

### 1. Kit Contents

<b>Description</b>	<b>Model No. 40-6028 &amp; 40-6048</b>	<b>Qty.</b>
Digital Level		1
“AAA” Alkaline Batteries		3
Instruction Manual		1
Carrying Case		1

### 2. Features and Functions

- LCD can rotate 180°
- 5 construction languages - units of measure (degrees, percent, mm/m, in/ft in decimal, in/ft in fractional)
- Self-calibrated
- 0° to 10° and 80° to 90°-position of inclination is confirmed by a signal tone
- Numbers invert for working overhead
- Reference function making any slope “0.0”
- Hold function locks measurement on the LCD

### 3. Location of Part/Components

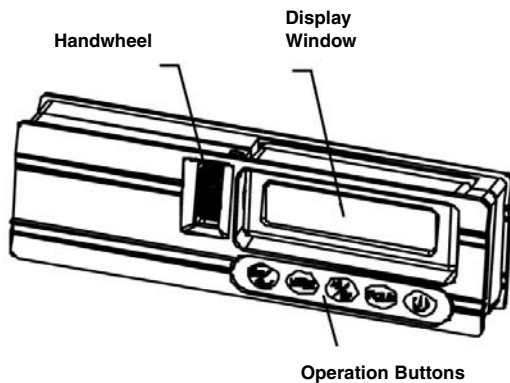

## 4. Operating Instructions

**IMPORTANT:** It is the responsibility of the user to verify the calibration of the instrument before each use.

### Battery Installation

1. Turn the electronic module off while taking out the old batteries from the battery case.
2. Open the battery cap, remove the old batteries and put in new ones.
3. Turn on the unit to see if all functions are correct.

### Note:

1. Be careful to follow the polarity symbol when replacing the batteries.
2. Take out the batteries if the electronic module is not going to be used for a long time.

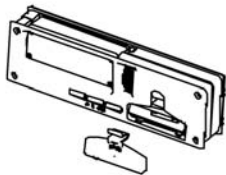

## 5. Using the Product

### Key Guide

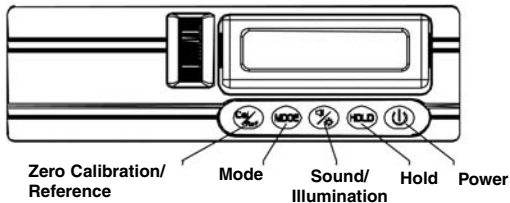

### Power Key

Turn on/off the electronic module. The electronic module will beep twice when turned on and beep once when turned off.

### Hold Key

Pressing this key will lock the current angle reading displayed on the LCD. At this time the measurement that you are measuring stays on your LCD. The arrows on each side of the digital readout blink in this function to remind you that you are in the HOLD function.

### Sound and LCD Illumination Key

Press this key once to turn on/off the sound function. The electronic module will beep once. When sound function is on you will see the horn symbol on the LCD. The level will not beep if the instrument is at  $10^\circ$  or more. The level will beep faster as you move closer to  $0.0^\circ$ . A solid tone will sound when level is at  $0.0^\circ$  or  $90\%$ . Press and hold this key for 3 seconds to turn on/off the LCD back light.

### Mode Key

Push the MODE button to switch from one dimension to another. This controls which dimension your electronic module will measure in. Your level has the capability to measure in Degrees, Percentage of slope, Millimeters per Meter, Inches per Foot (Slope, Pitch) in decimal form and Inches per Foot in fractions of an inch. A symbol on the upper right of the screen will explain which MODE you are currently in.

### Zero Calibration Key

Please refer to Section 6 “Self-check and calibration”.

### Auto Shut-off

The electronic module will automatically shut-off in 15-20 minutes if no key is pressed.

### Low Battery Indicator

When the battery voltage is low, the battery symbol will flash in the LCD, the battery will need to be replaced.

Battery Symbol



## Inclination Indication

The triangle arrows displayed on the two ends of the LCD indicate the inclination direction of the digital level.

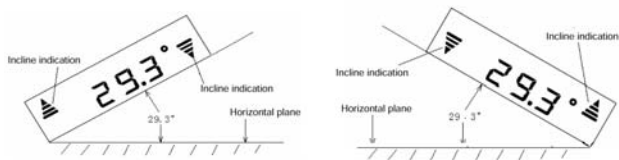

When the digital level is at the position of 0 degree, the two arrows will show as follows:



## Rotating Display

The LCD of the instrument can rotate 180 degrees.

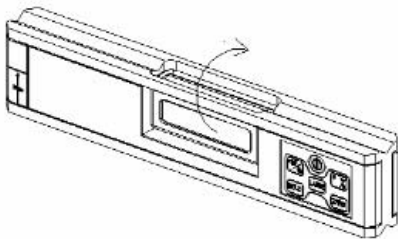

## 6. Self-Check and Calibration

**IMPORTANT:** It is the responsibility of the user to verify the calibration of the instrument before each use.

### Checking the Horizontal Calibration

Select a flat and horizontal platform as a reference surface, like a table-surface.

1. Place the digital level on this reference surface, as shown in figure 1, and then record the measured angle reading. Record this as A1.
2. Turn the digital level 180 degrees, as shown in figure 2, and then record the measured angle reading. Record this as A2.
3. If A1-A2 is greater than  $.2^{\circ}$ , it is necessary to calibrate the horizontal accuracy.



Fig. 1



Fig. 2



### Checking the Vertical Calibration

Select a flat and vertical platform as a reference surface.

1. Place the digital level on this reference surface, as shown in figure 3, and then record the measured angle reading. Record this as A1.
2. Turn the digital level 180 degrees, as shown in figure 4, and then record the measured angle reading. Record this as A2.
3. If A1-A2 is greater than  $.2^{\circ}$ , it is necessary to calibrate the vertical accuracy.

The same vertical reference surface

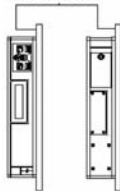

Fig. 3

Fig. 4



## Horizontal Calibration

1. Press and hold the CAL/REF key for 3-plus seconds, unit will beep once. When the LCD shows -0-, the digital level has entered the calibration mode.
2. Place the digital level on the horizontal reference surface, as shown in figure 5, after 10 seconds, press the CAL/REF again, and the LCD shows -1-.
3. Turn the digital level 180 degrees, as shown in figure 6, and after 10 seconds, press the CAL/REF key again, and the LCD shows -2-. Wait for 2 seconds, and the digital level will show the angle reading. The horizontal calibration is now completed.

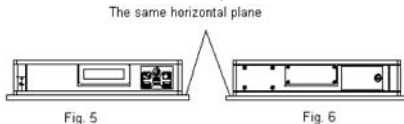

## Vertical Calibration

1. Press and hold the CAL/REF key for 3-plus seconds, unit will beep once. When the LCD shows -0-, the digital level has entered the calibration mode.
2. Place the digital level on the vertical reference surface, as shown in figure 7, after 10 seconds, press the CAL/REF again, and the LCD shows -1-.
3. Turn the digital level 180 degrees, as shown in figure 8, and after 10 seconds, press the CAL/REF key again, and the LCD shows -2-. Wait for 2 seconds, and the digital level will show the angle reading. The vertical calibration is now completed.

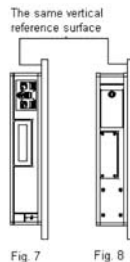

## 7. Technical Specifications

Range of Angle Measurement	360°, Display $\pm 90^\circ$
Definition Rate	0.1°
Accuracy	$\pm 0.1^\circ$ for 0° and 90° $\pm 0.2^\circ$ for other angles
Power Supply	3 “AAA” alkaline batteries
Battery Life	Approx. battery life 60 hours continuous use
Working Temperature	14°F to 113°F (-10°C to +45°C)

## 8. Care and Handling

- This unit is a precision tool that must be handled with care.
- Avoid exposing unit to shock vibrations and extreme temperatures.
- Before moving or transporting the unit, make sure that the unit is turned off.
- Remove the batteries when storing the unit for an extended time (more than three months) to avoid damage to the unit should the batteries deteriorate.
- Always store the unit in its case when not in use.
- Avoid getting the unit wet.
- Keep the unit dry and clean. Remove any moisture or dirt with a soft, dry cloth.

- Do not use harsh chemicals, strong detergents or cleaning solvents to clean the unit.

## 9. Product Warranty

Johnson Level & Tool offers a one year limited warranty on each its products. You can obtain a copy of the limited warranty for a Johnson Level & Tool product by contacting Johnson Level & Tool's Customer Service Department as provided below or by visiting us online at [www.johnsonlevel.com](http://www.johnsonlevel.com). The limited warranty for each product contains various limitations and exclusions.

**NOTE:** The user is responsible for the proper use and care of the product.

It is the responsibility of the user to verify the calibration of the instrument before each use.

For further assistance, or if you experience problems with this product that are not addressed in this instruction manual, please contact our Customer Service Department.

In the U.S., contact Johnson Level & Tool's Customer Service Department at 800-563-8553.

In Canada, contact Johnson Level & Tool's Customer Service Department at 800-346-6682.

